

MRX500

S E R I E S



M R X 5 1 2 M

M R X 5 1 5

M R X 5 2 5

M R X 5 1 8 S

M R X 5 2 8 S

The Ultimate Light Weight, High-Output Portable PA

MRX500
S E R I E S

Light Weight Heavy Duty

Constantly pushing the threshold for better, more useful products for the working musician and DJ, JBL Professional once again hits the target with the all new MRX500 Series Loudspeaker System. Compact, lightweight, truly portable, the MRX500 is the ultimate PA system for musicians and DJ's who need fully professional sound and performance within a budget.



Torture Tested and Road Proven

Featuring as much as 30% less weight than comparable systems, the MRX was designed from the ground up by JBL engineers utilizing brand new lightweight JBL Differential Drive® transducer technology, engineered for this application. Drawing on the vast engineering excellence established with the industry standard and road proven VERTEC® Professional Loudspeaker Series, the MRX delivers outstanding performance for the DJ and musician where a smaller, lighter, more portable system is required with no sacrifice in sound quality or durability. Specifically engineered for MRX and completing the design, a series of rugged plywood enclosures, covered with JBL's DuraFlex™ finish, a tough, textured scratch resistant surface, that ensures years of solid performance and professional good looks.

100 Hour Torture Test

Like all JBL Professional products, the MRX Series is brutalized in JBL's speaker torture test. Unique in the industry, the JBL torture test submits each component in the MRX Series to 100 hours of continuous, high level input, ensuring that the MRX will deliver its extraordinary sound even after years of tough handling and thousands of hours of performance.



Get Moving

MRX delivers outstanding performance where a smaller, lighter, more portable system is required with no sacrifice in sound quality or durability.



Superb Sound and High-Power Performance

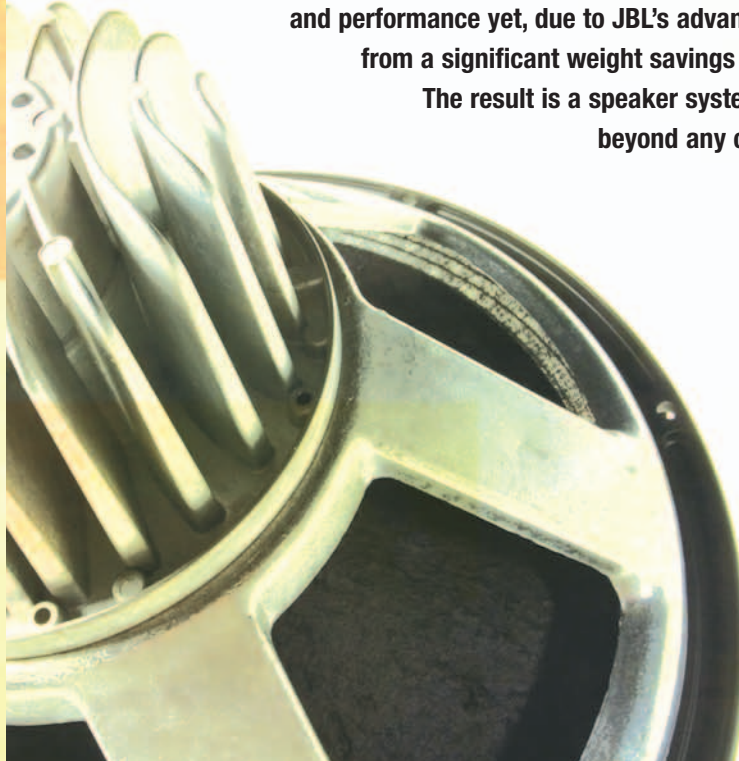

Taking a lead from the SRX700 Professional Loudspeaker System, these new components deliver extraordinary sound quality, power handling and performance yet, due to JBL's advanced engineering, benefit from a significant weight savings over traditional designs. The result is a speaker system that will perform well beyond any other system in its class.

Differential Drive Transducers

JBL Professional designed a brand new range of 400W Differential Drive® transducers in 12" and 15" configurations, perfectly matched to the brand new 1.5" annular polymer diaphragm compression driver producing a transducer engine that weighs significantly less than traditional transducer designs, yet their performance, sound quality and power handling are extraordinary.

Custom Waveguides

The constant beamwidth and power response of MRX500's custom designed waveguide is perfectly matched to its direct radiating woofers which ensures superb coverage throughout the frequency range of the system.

Engineered Enclosures

Combining mechanical design expertise, new materials and a DuraFlex™ finish, MRX500 enclosures have been optimized for minimum weight and maximum ruggedness.

Proven Networks

Utilizing years of design experience, MRX networks are built using proven components in the most sophisticated topologies in their class. For maximum reliability, all input and loop-thru connections are made via Neutrik® NL4MP connectors. In addition, the input connections can be easily reconfigured on the subs, for an efficient sub/sat cabling option.



Lighter. Louder. Legendary.

Dual Angle Pole Mount

The dual angle pole mount on the MRX512M and MRX515 offers much more control than the typical single mount. With a 10° down angle the speaker can be directed down toward your audience, keeping the energy off the back wall enhancing coverage and clarity.



Engineered to Move

Live Music

Performing musicians have long sought a system that is easy to transport, set up and adjust to the room, in very little time and typically with no assistance. Being your own sound man requires a hassle free system that is predictable and reliable, allowing you to quickly shift your focus back to the performance. The MRX is extraordinary in its coverage, allowing you to deliver super high quality JBL sound to every seat in the house.

Mobile DJ

DJ's are in constant need of wide bandwidth systems that can handle long hours of punishing, high decibel sound output with deep bass response, tight mids and crisp highs. But the mobile DJ must be able to achieve all this in an easily portable, super lightweight system. The MRX is without equal for this application, giving the flexibility, professional performance and road-tough durability that is as necessary as the quality of the sound.

Sound on the Move

The MRX line is a high quality portable PA that is truly portable. It's a perfect solution for houses of worship, schools or any venue that requires a mobile system. If you need a PA that is as easy to store as it is to use – compact, powerful and manageable, the MRX500 Series is your choice for sound on the move, even when it's just to the next room.





MRX512M



MRX515



MRX525



MRX528S



MRX518S

Specifications

MRX512M

System Type: 12" two-way stage utility / monitor speaker
 Frequency Range¹ (-10 dB): 60 Hz - 20k Hz
 Frequency Response² (±3 dB): 90 Hz - 20k Hz
 System Sensitivity (1w @ 1m): 97 dB SPL
 Nominal Impedance: 8 ohms
 Rated Maximum SPL: 123 dB SPL continuous (129 dB SPL peak)
 Power Rating (Continuous / Program / Peak): 400 W / 800 W / 1600 W³
 Coverage Pattern: 70° x 70° nominal
 LF Driver: 1 x JBL 262H 305 mm (12 in) Differential Drive[®] woofer
 HF Driver: 1 x JBL 2408H 37.5 mm (1.5 in) annular polymer diaphragm, neodymium compression driver
 Dimensions (H x W x D): 645 mm x 380 mm x 345 mm (25.25 in x 15.0 in x 13.5 in)
 Net Weight: 14.9 kg (33.0 lbs.)

MRX515

System Type: 15" two-way, bass-reflex
 Frequency Range¹ (-10 dB): 52 Hz - 20 kHz
 Frequency Response² (±3 dB): 65 Hz - 20 kHz
 System Sensitivity (1w @ 1m): 98 dB SPL
 Nominal Impedance: 8 ohms
 Rated Maximum SPL: 124 dB SPL continuous (130 dB SPL peak)
 Power Rating (Continuous / Program / Peak): 400 W / 800 W / 1600 W³
 Coverage Pattern: 70° x 70° nominal
 LF Driver: 1 x JBL 265H 380 mm (15 in) Differential Drive[®] woofer
 HF Driver: 1 x JBL 2408H 37.5 mm (1.5 in) annular polymer diaphragm, neodymium compression driver
 Dimensions (H x W x D): 700 mm x 435 mm x 470 mm (27.25 in x 17.5 in x 18.5 in)
 Net Weight: 19.5 kg (43 lbs.)

MRX525

System Type: Dual 15" two-way, bass-reflex
 Frequency Range¹ (-10 dB): 40 Hz - 20 kHz
 Frequency Response² (±3 dB): 57 Hz - 20 kHz
 System Sensitivity (1w @ 1m): 100 dB SPL
 Nominal Impedance: 4 ohms
 Rated Maximum SPL: 129 dB SPL Continuous (135 dB SPL Peak)
 Power Rating (Continuous / Program / Peak): 800 W / 1600 W / 3200 W³
 Coverage Pattern: 70° x 70° nominal
 LF Driver: 2 x JBL 265H 380 mm (15 in) Differential Drive[®] woofer
 HF Driver: 1 x JBL 2408H 37.5 mm (1.5 in) annular polymer diaphragm, neodymium compression driver
 Dimensions (H x W x D): 1240 mm x 535 mm x 460 mm (48.75 in x 21.0 in x 18.0 in)
 Net Weight: 38.2 kg (84 lbs.)

MRX528S

System Type: Dual 18" bass-reflex subwoofer
 Frequency Range¹ (-10 dB): 35 Hz - 250 Hz
 Frequency Response² (±3 dB): 40 Hz - 250 Hz
 System Sensitivity (1w @ 1m): 103 dB SPL³
 Nominal Impedance: 4 ohms
 Rated Maximum SPL: 133 dB SPL continuous (139 dB SPL peak)³
 Power Rating (Continuous / Program / Peak): 1000 W / 2000 W / 4000 W²
 Coverage Pattern: 70° x 70° nominal
 LF Driver: 2 x JBL 2044H 457 mm (18 in) woofers
 Dimensions (H x W x D): 1095 mm x 535 mm x 700 mm (43 in x 21 in x 27.5 in)
 Net Weight: 55 kg (121 lbs.)

MRX518S

System Type: 18" bass-reflex subwoofer
 Frequency Range¹ (-10 dB): 40 Hz - 200 Hz
 Frequency Response² (±3 dB): 45 Hz - 200 Hz
 System Sensitivity (1w @ 1m): 100 dB SPL³
 Nominal Impedance: 4 ohms
 Rated Maximum SPL: 127 dB SPL continuous (133 dB SPL peak)³
 Power Rating (Continuous / Program / Peak): 500 W / 1000 W / 2000 W²
 LF Driver: 1 x JBL 2044G 457 mm (18 in) woofers
 Dimensions (H x W x D): 560 mm x 535 mm x 700 mm (22 in x 21 in x 27.5 in)
 Net Weight: 32.5 kg (72 lbs.)

Available Accessories

SS3-BK 35 mm diameter, 1041 mm (41") speaker pole for MRX518S and MRX512M or MRX515
 SS2-BK Tripod Stand for MRX512M or MRX515

8500 Balboa Boulevard
 Northridge, CA 91329 USA
 Visit us online at www.jblpro.com



A Harman International Company

MRX500

S E R I E S

User's Guide

MRX512M

MRX515

MRX525

MRX518S

MRX528S



CONTENTS

Before You Begin - Important Information 2

Product Specifications 3-5

Recommended Amplifiers, Infrasonic Filters, DuraFlex™ and Pole Mounting 5-6

MRX Series Block Diagram 7-9

Basic Configuration 10

Sub/Sat Configuration 11

Speaker Cables 12

JBL Limited Warranty 13

JBL Professional Contacts 14

Explanation of Graphic Symbols



The exclamation point within an equilateral triangle is intended to alert the users to the presence of important operating and maintenance (servicing) instructions in the literature accompanying the product.



The lightning flash with the arrowhead symbol, within an equilateral triangle, is to alert the user to the presence of insulated "dangerous voltage" within the products enclosure that may be of sufficient magnitude to constitute a risk of electric shock to humans.



CAUTION: TO REDUCE THE RISK OF ELECTRONIC SHOCK - DO NOT REMOVE COVER. NO USER SERVICEABLE PARTS INSIDE. REFER SERVICING TO QUALIFIED PERSONNEL.



ATTENTION: POUR EVITER LES RISQUES DE CHOC ELECTRIQUE, NE PAS ENLEVER LE COUVERCLE. AUCUN ENTRETIEN DE PIECES INTERIEURES PAR L'USAGER. CONFIER L'ENTRETIEN AU PERSONNEL QUALIFIE. AVIS: POUR EVITER LES RISQUES D'INCENDIE OU D'ELECTROCUTION, N'EXPOSEZ PAS CET ARTICLE A LA PLUIE OU A L'HUMIDITE.



The IEC fuse symbol pictured at the left represents an approved user replaceable fuse. When replacing a fuse, make sure to replace with only the correct type and fuse rating.

Important Safety Instructions

1. Read these instructions.
2. Keep these instructions.
3. Heed all warnings
4. Follow all instructions
5. Do not use this apparatus near water.
6. Clean only with a dry cloth.
7. Do not block any ventilation openings. Install in accordance with manufacturers instructions.
8. Do not install near any heat sources such as radiators, heat registers, stoves, or other apparatus that produce heat.
9. Do not defeat the safety purpose of the polarized or grounding-type plug. A polarized plug has two blades with one wider than the other. A grounding-type has two blades and a third grounding prong. The wide blade or the third prong is provided for your safety. If the provided plug does not fit your outlet, consult a electrician for replacement of the obsolete outlet.
10. Protect the power cord from being walked on or pinched, particularly at plugs, convenience receptacles, and the point where they exit the apparatus.
11. Only use attachments / accessories specified by the manufacturer.
12. Use only with a cart, stand, bracket, or table specified by the manufacturer or sold with the apparatus. When a cart is used, use caution when moving the cart / apparatus combination to avoid injury from tip-over.
13. Unplug this apparatus during lightning storms or when un-used for long periods of time.
14. Refer all servicing to qualified service personnel. Servicing is required when a apparatus has been damaged in any way, such as power-cord or plug is damaged, liquid has been spilled, or objects have fallen into the apparatus, the apparatus has been exposed to rain or moisture, does not operate normally, or has been dropped.
15. To reduce the risk of fire or electric shock, do not expose this apparatus to rain or moisture.

BEFORE YOU BEGIN

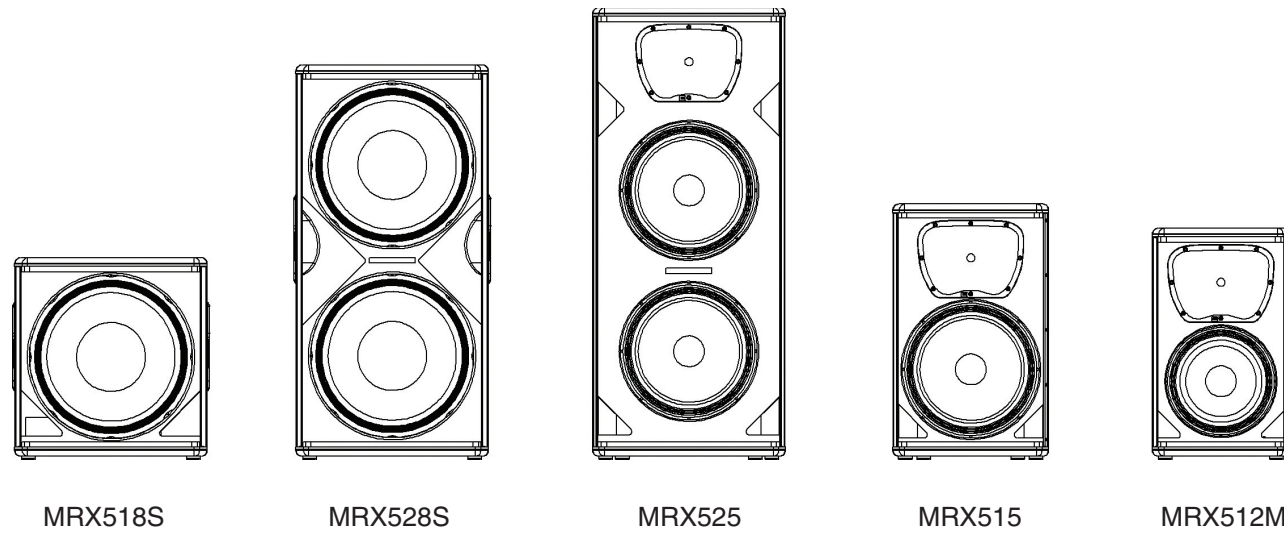

The MRX500 speakers covered by this manual are not intended for fixed installation in outdoor or high moisture environments. Moisture can damage the speaker cone and surround and cause corrosion of electrical contacts and metal parts. Avoid exposing the speakers to direct moisture. Keep speakers out of extended or intense direct sunlight. The driver suspension will prematurely dry out and finished surfaces may be degraded by long-term exposure to intense ultra-violet (UV) light.

MRX500 speakers can generate considerable energy. When placed on a slippery surface such as polished wood or linoleum, the speaker may move due to its acoustical energy output. Precautions should be taken to assure that the speaker does not fall off a stage or table on which it is placed.

Stand mounting safety precautions

Some MRX500 models include a 35 mm receptacle cup to allow mounting on tripod stands or on a pole over subwoofers. When using stands or poles, be sure to observe the following precautions:

- ▶ Check the stand or pole specification to be certain the device is designed to support the weight of the speaker. Observe all safety precautions specified by the manufacturer.
- ▶ Always verify that the stand (or subwoofer / pole) is placed on a flat, level, and stable surface and be sure to fully extend the legs of tripod type stands. Position the stand so that the legs do not present a trip hazard.
- ▶ Route cables so that performers, production crew, and audience will not trip and topple the speakers over.
- ▶ Inspect the stand (or pole and associated hardware) before each use and do not use equipment with worn, damaged, or missing parts.
- ▶ Do not attempt to place more than one MRX500 speaker on a stand or pole.
- ▶ Always be cautious in windy, outdoor conditions. It may be necessary to place additional weight (i.e. sand bags) on the base of the stand to improve stability. Avoid attaching banners or similar items to any part of a speaker system. Such attachments could act as a sail and topple the system.
- ▶ Unless you are confident that you can handle the weight of the speaker, ask another person to help you get it onto the tripod stand or pole.

Hearing damage, prolonged exposure to excessive SPL

MRX500 loudspeakers are easily capable of generating sound pressure levels (SPL) sufficient to cause permanent hearing damage to performers, production crew and audience members. Caution should be taken to avoid prolonged exposure to SPL in excess of 90 dB.

SPECIFICATIONS

MRX512M - 12", two-way, bass-reflex, utility / monitor speaker

Frequency Range (-10 dB):	60 Hz - 20 kHz
Frequency Response (±3 dB):	90 Hz - 20 kHz
Coverage Pattern:	70° x 70° nominal
Crossover Mode:	Passive
Crossover Frequency:	1.7 kHz
Power Rating:	400 W / 800 W / 1600 W, 2 hrs ¹
(Continuous / Program / Peak)	350 W / 700 W / 1400 W, 100 hrs ¹
Maximum SPL:	123 dB SPL continuous (129 dB SPL peak) ²
System Sensitivity (1w @ 1m):	97 dB SPL
LF Driver:	1 x JBL 262H 305 mm (12 in) Differential Drive® woofer
HF Driver:	1 x JBL 2408H 37.5 mm (1.5 in) annular polymer diaphragm, neodymium compression driver
Nominal Impedance:	8 ohms
Enclosure:	Symmetrical stage monitor, 15/18 mm, plywood.
Suspension/Mounting:	Dual-angle (0° or -10°), 35 mm pole socket
Transport:	Integrated handle / input cup
Finish:	Black DuraFlex™ finish
Grille:	Powder coated, black, 16 gauge perforated steel with acoustically transparent black screen backing.
Input Connectors:	Neutrik® Speakon® NL-4 (x2), one on each end
Dimensions (H x W x D):	645 mm x 380 mm x 345 mm (25.25 in x 15.0 in x 13.5 in)
Net Weight:	14.9 kg (33 lb)
Optional Accessories:	SS2-BK: Tripod speaker stand SS3-BK: Satellite speaker pole

¹ IEC standard, full bandwidth pink noise with 6 dB crest factor for specified period

² Calculated based on power rating and sensitivity

MRX515 - 15" two-way, bass-reflex

Frequency Range (-10 dB):	52 Hz - 20 kHz
Frequency Response (±3 dB):	65 Hz - 20 kHz
Coverage Pattern:	70° x 70° nominal
Crossover Mode:	Passive
Crossover Frequency:	1.7 kHz
Power Rating :	400 W / 800 W / 1600 W, 2 hrs ¹
(Continuous / Program / Peak)	350 W / 700 W / 1400 W, 100 hrs ¹
Maximum SPL:	124 dB SPL continuous (130 dB SPL peak) ²
System Sensitivity (1w @ 1m):	98 dB SPL
LF Driver:	1 x JBL 265H 380 mm (15 in) Differential Drive® woofer
HF Driver:	1 x JBL 2408H 37.5 mm (1.5 in) annular polymer diaphragm, neodymium compression driver
Nominal Impedance:	8 ohms
Enclosure:	Trapezoidal, 15/18 mm, plywood
Suspension/Mounting:	Dual-angle (0° or -10°) 35 mm pole socket
Transport:	2 x die-cast handles with backing cup
Finish:	Black DuraFlex™ finish
Grille:	Powder coated, black, 16-gauge perforated steel with acoustically transparent black screen backing.
Input Connectors:	Neutrik® Speakon® NL-4 (x2)
Dimensions (H x W x D):	700 mm x 435 mm x 470 mm (27.25 in x 17.5 in x 18.5 in)
Net Weight:	19.5 kg (43 lb)
Optional Accessories:	SS2-BK: Tripod speaker stand SS3-BK: Satellite speaker stand

¹ IEC standard, full bandwidth pink noise with 6 dB crest factor for specified period

² Calculated based on power rating and sensitivity.

SPECIFICATIONS

MRX525 - Dual 15", two-way, bass-reflex

Frequency Range (-10 dB):	40 Hz - 20 kHz
Frequency Response (±3 dB):	57 Hz - 20 kHz
Coverage Pattern:	70° x 70° nominal
Crossover Mode:	Passive
Crossover Frequency:	1.8 kHz
Power Rating:	800 W / 1600 W / 3200 W, 2 hrs ¹
(Continuous / Program / Peak)	700 W / 1400 W / 2800 W, 100 hrs ¹
Maximum SPL:	129 dB SPL continuous (135 dB SPL peak) ²
System Sensitivity (1w @ 1m):	100 dB SPL
LF Driver:	2 x JBL 265H 380 mm (15 in) Differential Drive [®] woofers
HF Driver:	1 x JBL 2408H 37.5 mm (1.5 in) annular polymer diaphragm, neodymium compression driver
Nominal Impedance:	4 ohms
Enclosure:	Trapezoidal, 15/18 mm, plywood
Transport:	2 x die-cast handles with backing cup
Finish:	Black DuraFlex™ finish
Grille:	Powder coated, black, 16-gauge perforated steel with acoustically transparent black screen backing.
Input Connectors:	Neutrik® Speakon® NL-4 (x2)
Dimensions (H x W x D):	1240 mm x 535 mm x 460 mm; (48.75 in x 21.0 in x 18.0 in)
Net Weight:	38.2 kg (84 lb)

¹ IEC standard, full bandwidth pink noise with 6 dB crest factor for specified period

² Calculated based on power rating and sensitivity

MRX528S - Dual 18" bass-reflex subwoofer

Frequency Range (-10 dB):	35 Hz - 250 Hz
Frequency Response (±3 dB):	40 Hz - 250 Hz
Input Connection Modes:	Internally configurable, +1/-1 or +2/-2
Recommended Crossover Frequencies:	80-120 Hz, 24-48 dB/octave
Power Rating:	1000 W / 2000 W / 4000 W, 2 hrs ¹
(Continuous / Program / Peak)	800 W / 1600 W / 3200 W, 100 hrs ¹
Maximum SPL:	133 dB SPL continuous (139 dB SPL peak) ²
System Sensitivity (1w @ 1m):	97 dB SPL; 103 dB SPL ²
LF Driver:	2 x JBL 2044H 457 mm (18 in) woofers
Nominal Impedance:	4 ohms
Enclosure:	Rectangular, 18 mm, birch plywood
Finish:	Black DuraFlex™ finish
Grille:	Powder coated, black, 16 gauge perforated steel with acoustically transparent black screen backing.
Input Connectors:	Neutrik® Speakon® NL-4 (x2)
Dimensions (H x W x D):	1095 mm x 535 mm x 700 mm (43 in x 21 in x 27.5 in)
Net Weight:	55 kg (121 lb)

¹ 40 Hz to 400 Hz pink noise with 6 dB crest factor for specified period

² Calculated on half space condition

SPECIFICATIONS

MRX518S - 18" bass-reflex subwoofer

Frequency Range (-10 dB):	40 Hz - 200 Hz
Frequency Response (±3 dB):	45 Hz - 200 Hz
Input Connection Modes:	Internally configurable, +1/-1, +2/-2
Recommended Crossover Frequencies:	80-120 Hz, 24-48 dB/octave HPF
Power Rating :	500 W / 1000 W / 2000 W, 2 hrs ¹
(Continuous / Program / Peak)	400 W / 800 W / 1600 W, 100 hrs ¹
Maximum SPL:	127 dB SPL continuous (133 dB SPL peak) ²
System Sensitivity (1w @ 1m):	94 dB SPL, 100 dB SPL ²
LF Driver:	1 x JBL 2044G 457 mm (18 in) woofer
Nominal Impedance:	4 ohms
Mounting:	Top mounted 35 mm socket for optional SS3-BK pole
Enclosure:	Rectangular, 18 mm, plywood
Finish:	Black DuraFlex™ finish
Grille:	Powder coated, black, 16 gauge perforated steel with acoustically transparent black screen backing.
Input Connectors:	Neutrik® Speakon® NL-4 (x2)
Dimensions (H x W x D):	560 mm x 535 mm x 700 mm (22 in x 21 in x 27.5 in)
Net Weight:	32.5 kg (72 lb)
Optional Accessories:	SS3-BK; Satellite speaker pole

¹ 40 Hz to 400 Hz pink noise with 6 dB crest factor for specified period

² Calculated on half space condition

Recommended Amplifier Power

Model	Recommended Amplifier Power	Infrasonic Filter Settings
	Full-Range / Parallel	HPF 24dB/octave
MRX512M	800 to 1,600W@8Ω	63 Hz
MRX515	800 to 1,600W@8Ω	50 Hz
MRX525	1,600 to 3,200W@4Ω	40 Hz
MRX518S	1,000 to 2,000W@4Ω	31 Hz
MRX528S	2,000 to 4,000W@4Ω	31 Hz

Infrasonic Filter Settings

It is a good practice to use a High Pass Filter (HPF) to prevent frequencies below the system tuning frequency from reaching the speaker. Inputting these frequencies to the speaker will not result in any appreciable acoustic output but will put needless mechanical stress on the woofer and reduce available amplifier headroom. A High Pass Filter will protect your MRX500 system from excess infrasonic energy with little, if any loss of significant program content. Refer to the above chart for infrasonic filter settings.

DuraFlex™ Finish

The DuraFlex finish used on your MRX500 series speakers is one of the most rugged finishes ever applied to a speaker. However, all speaker finishes are subject to damage. Should the DuraFlex finish require repair, a touch-up kit (Part Number 16677) is available from JBL Professional Parts.

Single Box On Pole Coverage

The dual angle pole socket on the MRX512M and MRX515 provides flexibility in aiming the speaker. As a general rule, the speaker should be positioned so that the audience cannot see the top or bottom panels of the speaker. When using stands or poles, be sure to observe the following precautions:

- Check the stand or pole specification to be certain the device is designed to support the weight of the speaker. Observe all safety precautions specified by the manufacturer.
- Be certain that the surface on which the system is to be stacked is flat, stable and solid.
- Route cables so that performers, production crew and audience will not trip and topple the speakers.
- Inspect the stand (or pole and assorted hardware) before each use and do not use equipment with worn, damaged or missing parts.
- Always be cautious when deploying the system outdoors. Unexpected winds may topple a system. It may be necessary to place additional weight (i.e. sandbags) on the base of the stand to improve stability. Avoid attaching banners or similar items to any part of the speaker system. Such attachments could act as a sail and topple the system.
- Unless you are confident that you can handle the weight of the speaker, ask another person to help you get it onto the stand or pole.

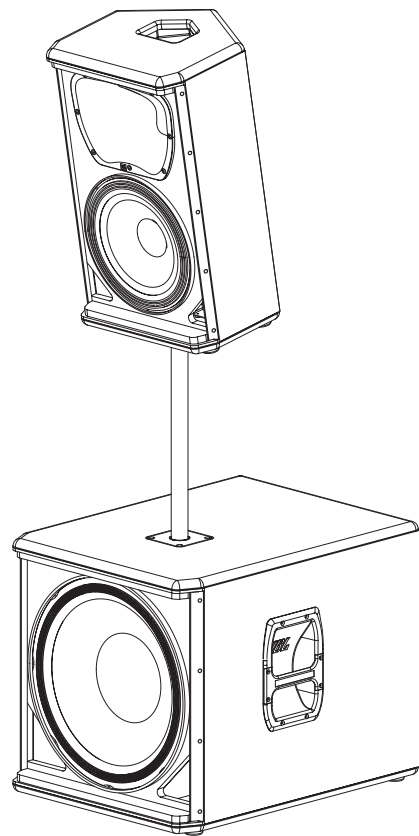

MRX500 SERIES BLOCK DIAGRAMS

MRX512M

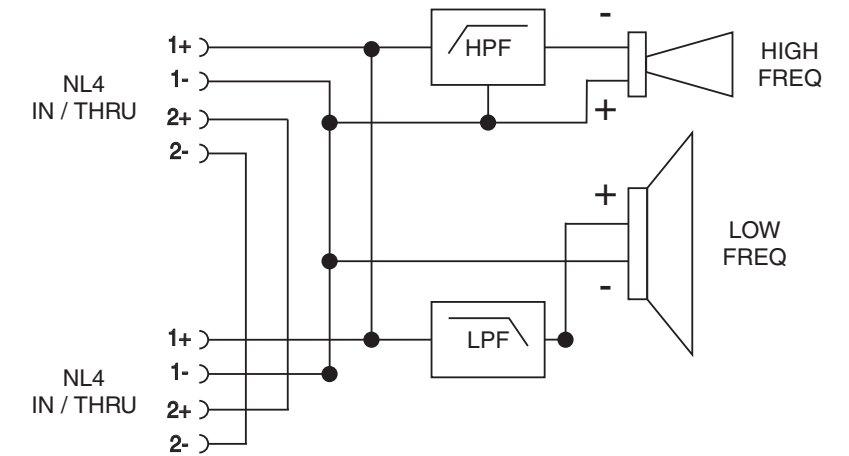
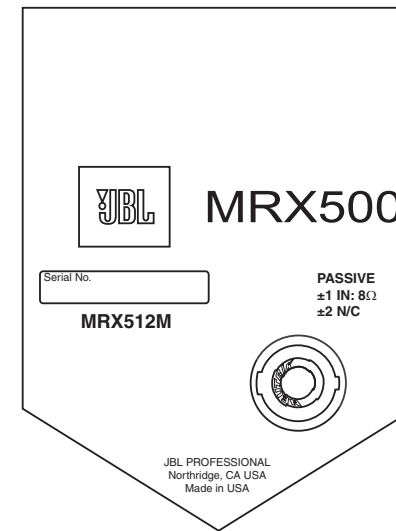

*MRX512M: Input panels are located at either end of the enclosure.

MRX515

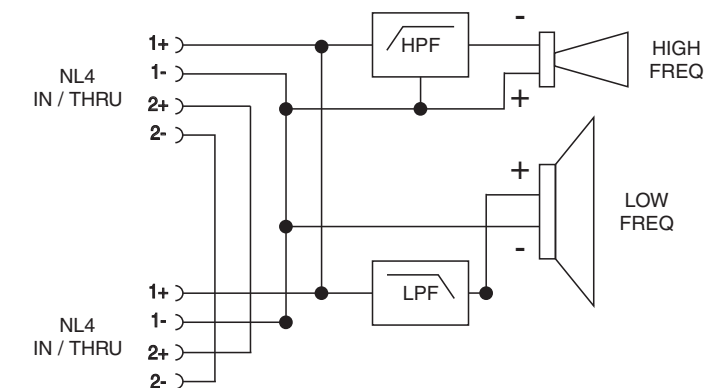
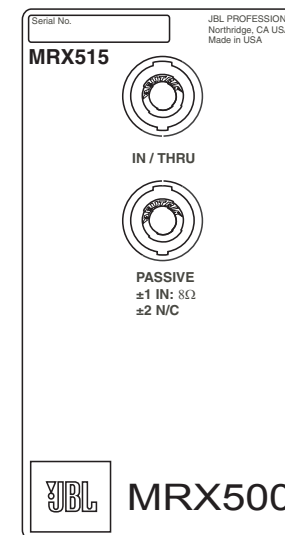

MRX500 SERIES BLOCK DIAGRAMS

MRX518S

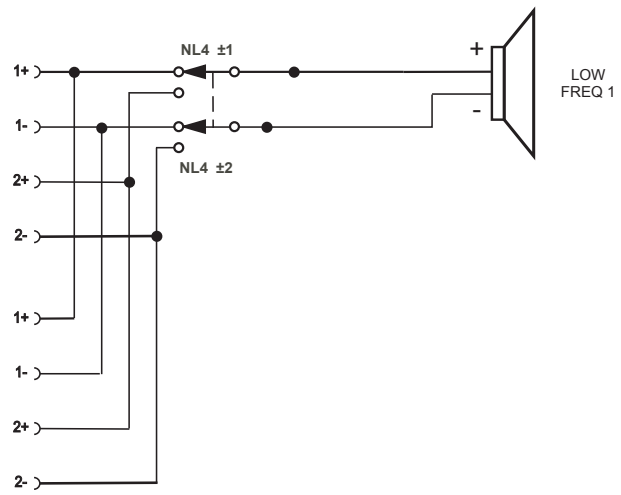
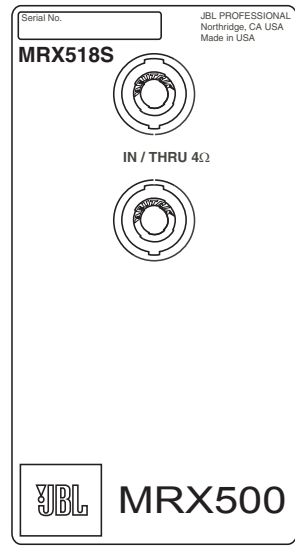

MRX525

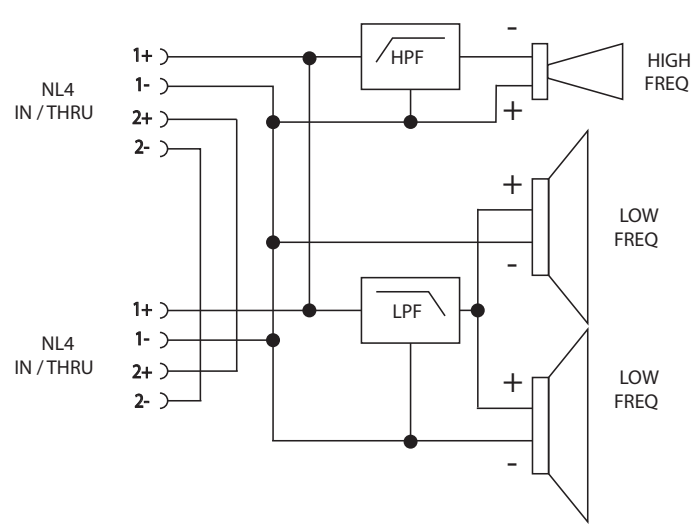
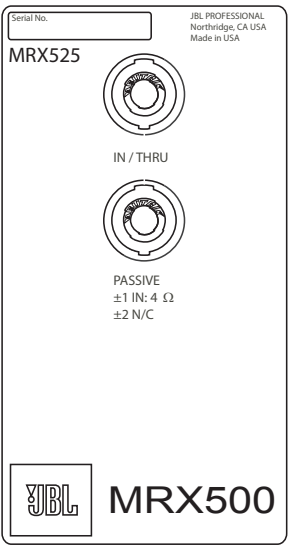

MRX500 SERIES BLOCK DIAGRAMS

MRX528S

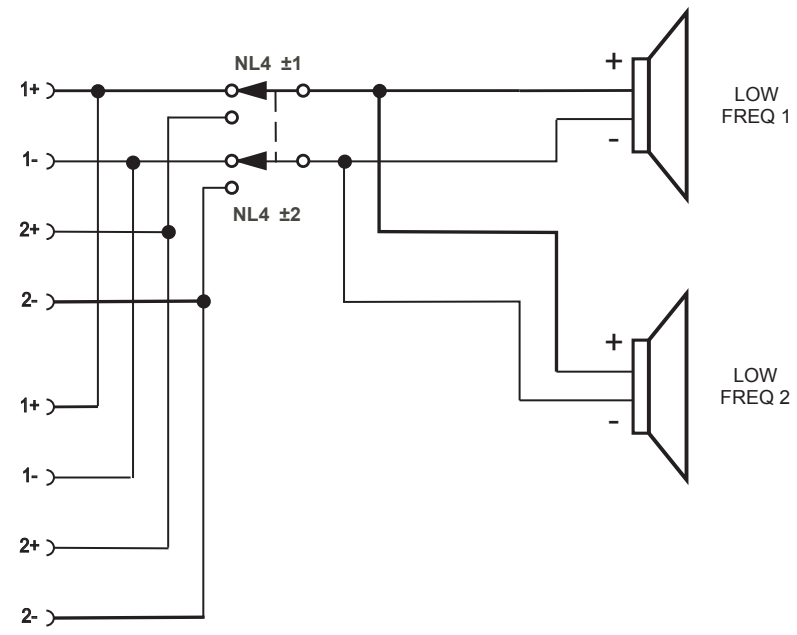
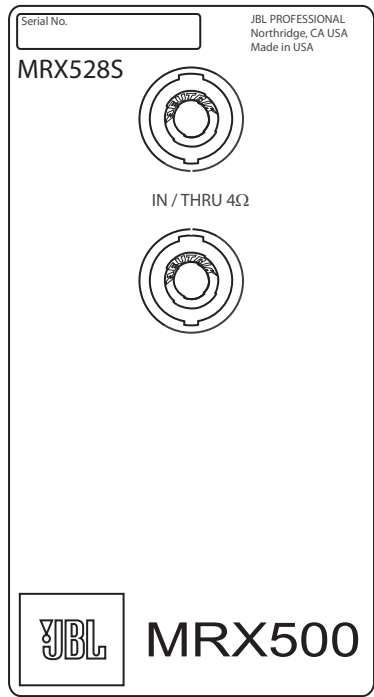

BASIC CONFIGURATION

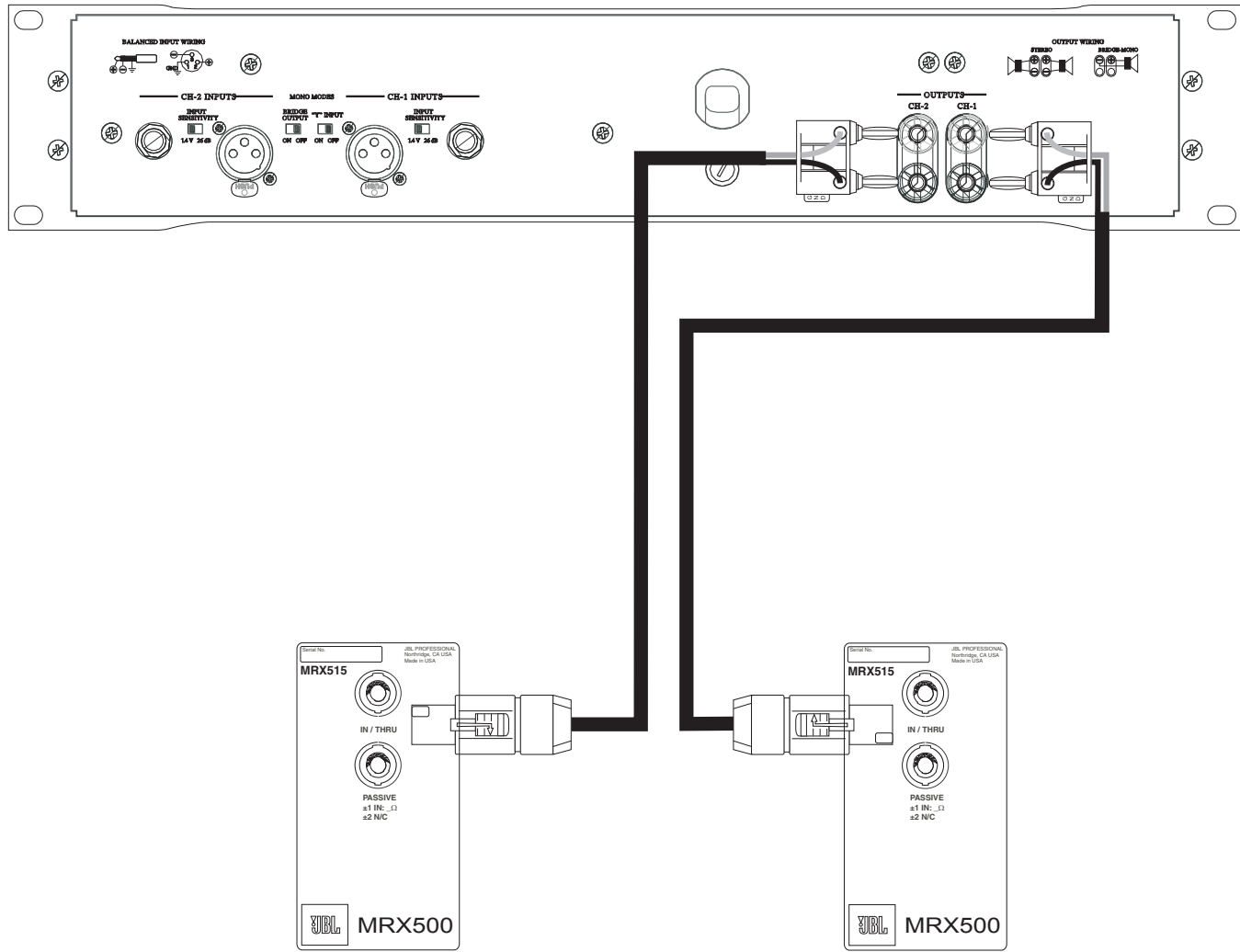

*MRX512M: Input panel has the same number of connectors, but are located at either end of the enclosure.

SUB/SAT WIRING

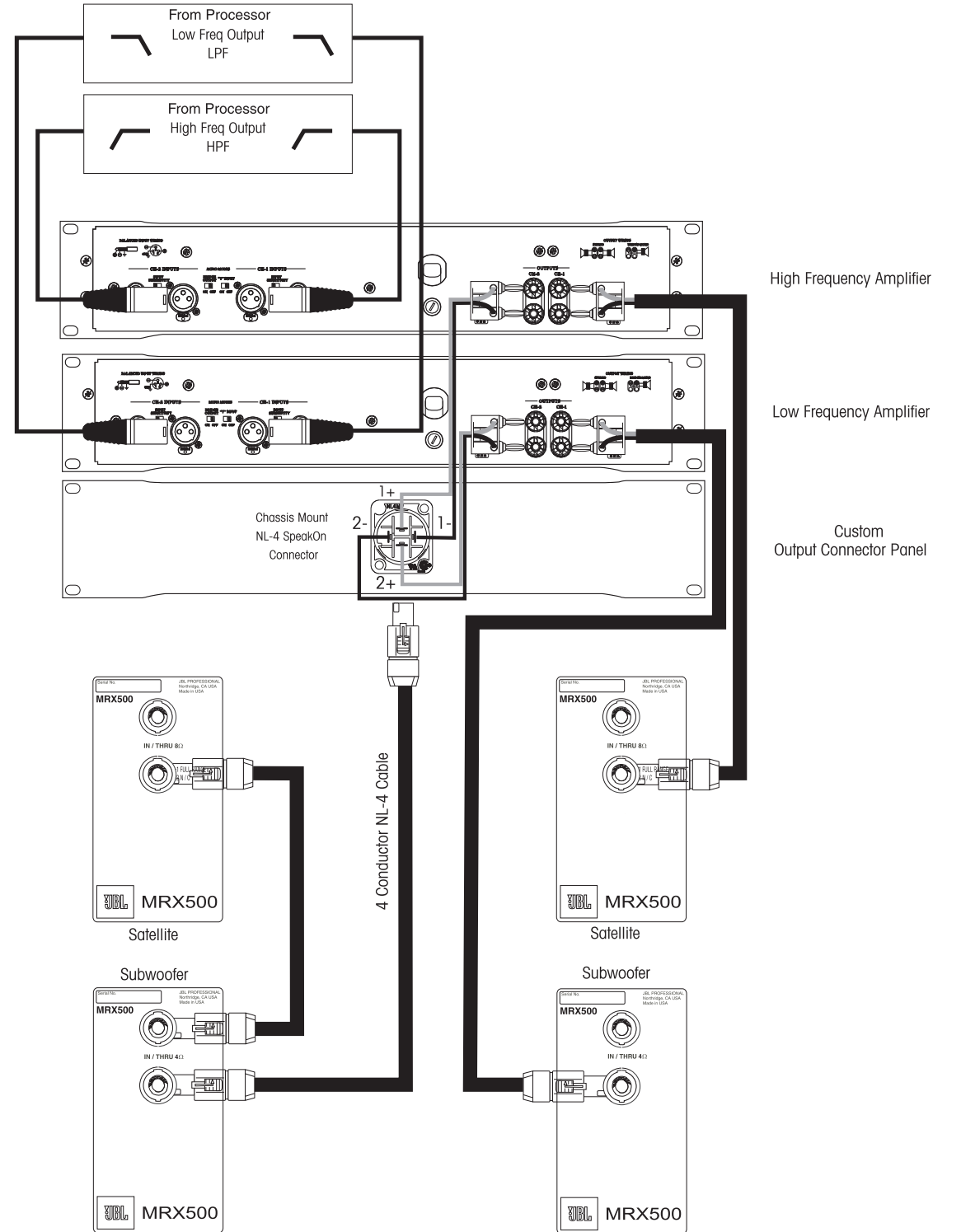

Using 4-Conductor Cable, Subwoofer configured for Pins 2±. (See Block Diagram)

Using 2-Conductor Cable, Subwoofer configured for Pins 1±. (See Block Diagram)

Speaker Cables

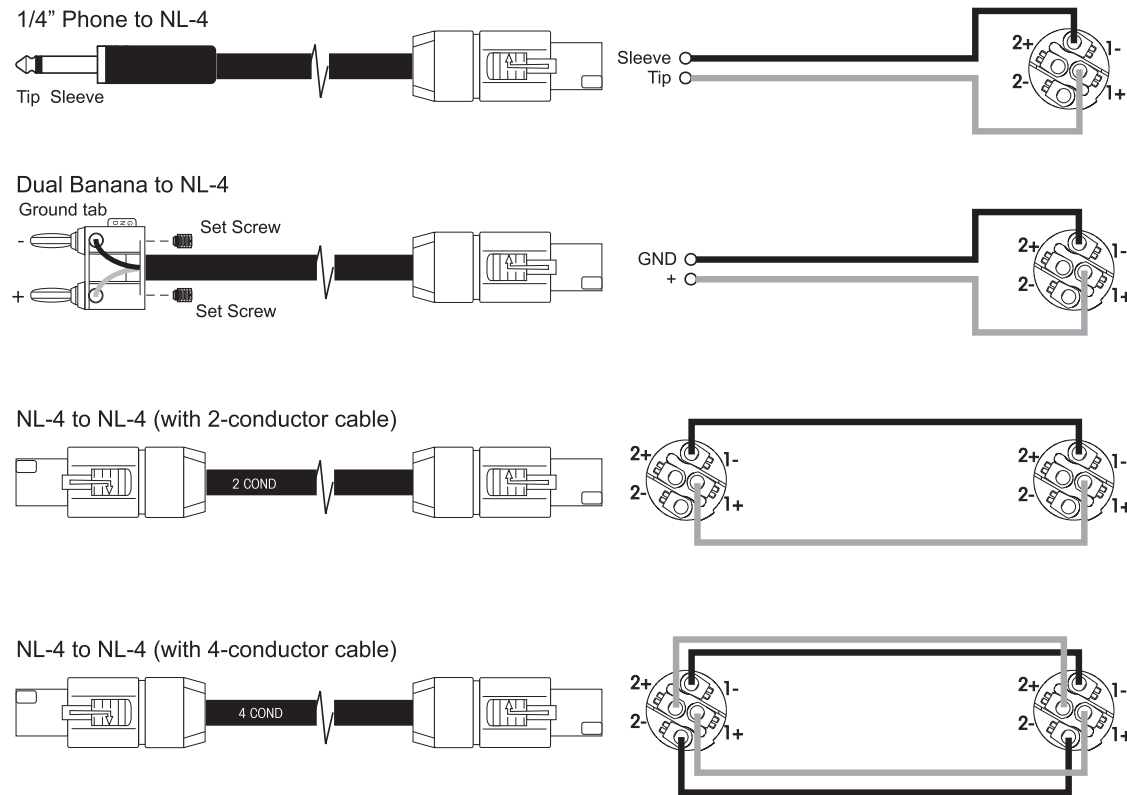

Minimum Wire Size for 0.5 dB Loss

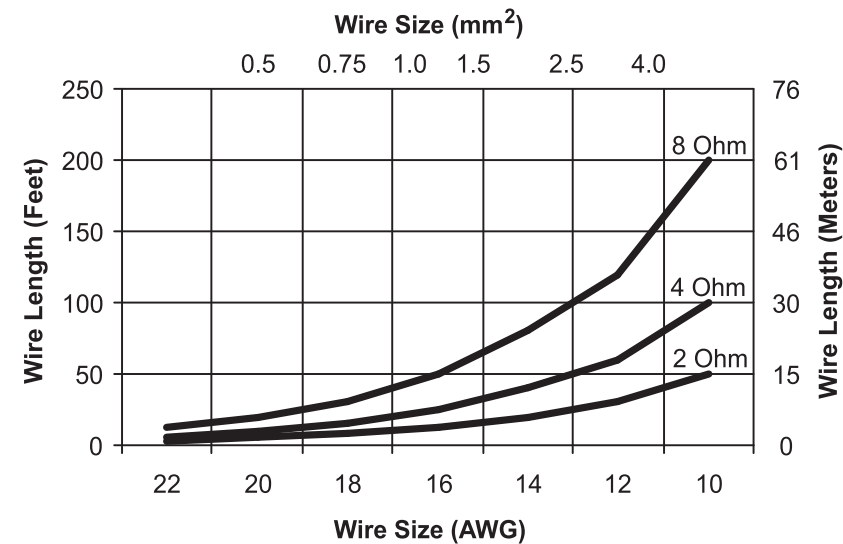

JBL LIMITED WARRANTY

The JBL Limited Warranty on professional loudspeaker products (except for enclosures) remains in effect for five years from the date of the first consumer purchase. JBL amplifiers are warranted for three years from the date of original purchase. Enclosures and all other JBL products are warranted for two years from the date of original purchase.

Who Is Protected by This Warranty?

Your JBL Warranty protects the original owner and all subsequent owners so long as: A.) Your JBL product has been purchased in the Continental United States, Hawaii or Alaska. (This Warranty does not apply to JBL products purchased elsewhere except for purchases by military outlets. Other purchasers should contact the local JBL distributor for warranty information.); and B.) The original dated bill of sale is presented whenever warranty service is required.

What does the JBL Warranty cover?

Except as specified below, your JBL Warranty covers all defects in material and workmanship. The following are not covered: Damage caused by accident, misuse, abuse, product modification or neglect; damage occurring during shipment; damage resulting from failure to follow instructions contained in your Instruction Manual; damage resulting from the performance of repairs by someone not authorized by JBL; claims based upon any misrepresentations by the seller; any JBL product on which the serial number has been defaced, modified or removed.

Who Pays for What?

JBL will pay all labor and material expenses for all repairs covered by this warranty. Please be sure to save the original shipping cartons because a charge will be made if replacement cartons are requested. Payment of shipping charges is discussed in the next section of this warranty.

How to Obtain Warranty Performance

If your JBL product ever needs service, write or telephone us at JBL Incorporated (Attn: Customer Service Department), 8500 Balboa Boulevard, PO. Box 2200, Northridge, California 91329 (818/893-8411). We may direct you to an authorized JBL Service Agency or ask you to send your unit to the factory for repair. Either way, you'll need to present the original bill of sale to establish the date of purchase. Please do not ship your JBL product to the factory without prior authorization. If transportation of your JBL product presents any unusual difficulties, please advise us and we may make special arrangements with you. Otherwise, you are responsible for transporting your product for repair or arranging for its transportation and for payment of any initial shipping charges. However, we will pay the return shipping charges if repairs are covered by the warranty.

Limitation of Implied Warranties

ALL IMPLIED WARRANTIES, INCLUDING WARRANTIES OF MERCHANTABILITY AND FITNESS FOR PARTICULAR PURPOSE, ARE LIMITED IN DURATION TO THE LENGTH OF THIS WARRANTY.

EXCLUSION OF CERTAIN DAMAGES

JBL'S LIABILITY IS LIMITED TO THE REPAIR OR REPLACEMENT, AT OUR OPTION, OF ANY DEFECTIVE PRODUCT AND SHALL NOT INCLUDE INCIDENTAL OR CONSEQUENTIAL DAMAGES OF ANY KIND. SOME STATES DO NOT ALLOW LIMITATIONS ON HOW LONG AN IMPLIED WARRANTY LASTS AND/OR DO NOT ALLOW THE EXCLUSION OF INCIDENTAL OR CONSEQUENTIAL DAMAGES, SO THE ABOVE LIMITATIONS AND EXCLUSIONS MAY NOT APPLY TO YOU. THIS WARRANTY GIVES YOU SPECIFIC LEGAL RIGHTS, AND YOU MAY ALSO HAVE OTHER RIGHTS, WHICH VARY, FROM STATE TO STATE.

JBL PROFESSIONAL CONTACTS

Mailing Address:

JBL Professional
8500 Balboa Blvd.
Northridge, CA 91329

Shipping Address:

JBL Professional
8370 Balboa Blvd., Dock D
Northridge, CA 91329
(Do not return product to this address without
first obtaining prior authorization from JBL)

Customer Service:

Monday through Friday
8:00am - 5:00pm
Pacific Coast Time In the U.S.A.
(800) 8JBLPRO (800.852.5776)
www.jblproservice.com

On the World Wide Web:

www.jblpro.com

Outside the USA:

Contact the JBL Professional Distributor in your area. A
complete list of JBL Professional international distributors is
provided at our U.S.A. website - www.jblpro.com

Product Registration:

Register your product online at www.jblpro.com/registration

Notes

Notes

Notes

MRX500

S E R I E S

Part Number: 362053-001

8500 Balboa Boulevard
Northridge, CA 91329 USA
Visit us online at www.jblpro.com



 A Harman International Company